

617222-001

ENCLOSURE: DRIPPROOF
 MOUNTING: FOOT
 DRIVE METHOD: COUPLED OR BELTED

RPMAC VARIABLE SPEED ALTERNATING CURRENT MOTOR RL & URL2586Z

COOLING: FORCE VENTILATED
 ACCESSORIES: PROVISIONS FOR
 TACHOMETER MOUNTING
 ONLY WHEN SPECIFIED

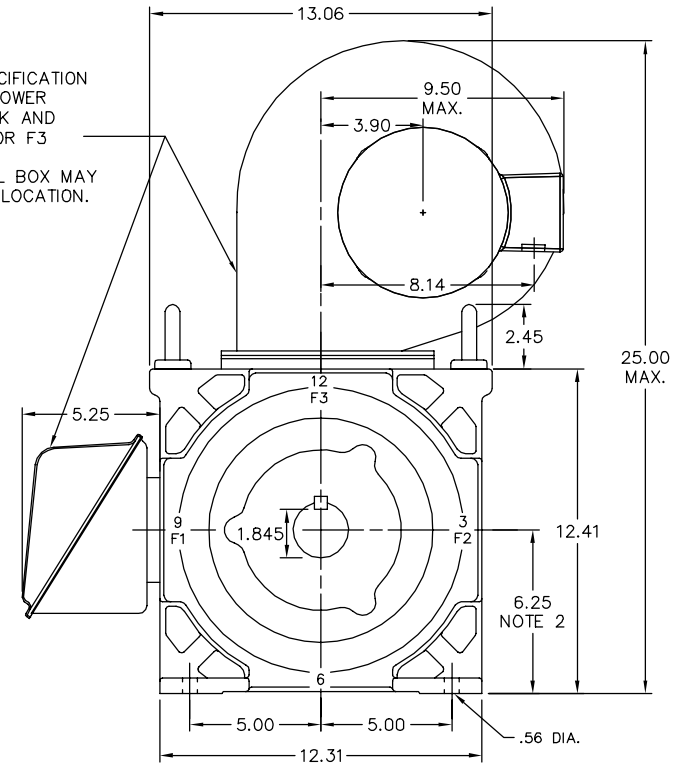
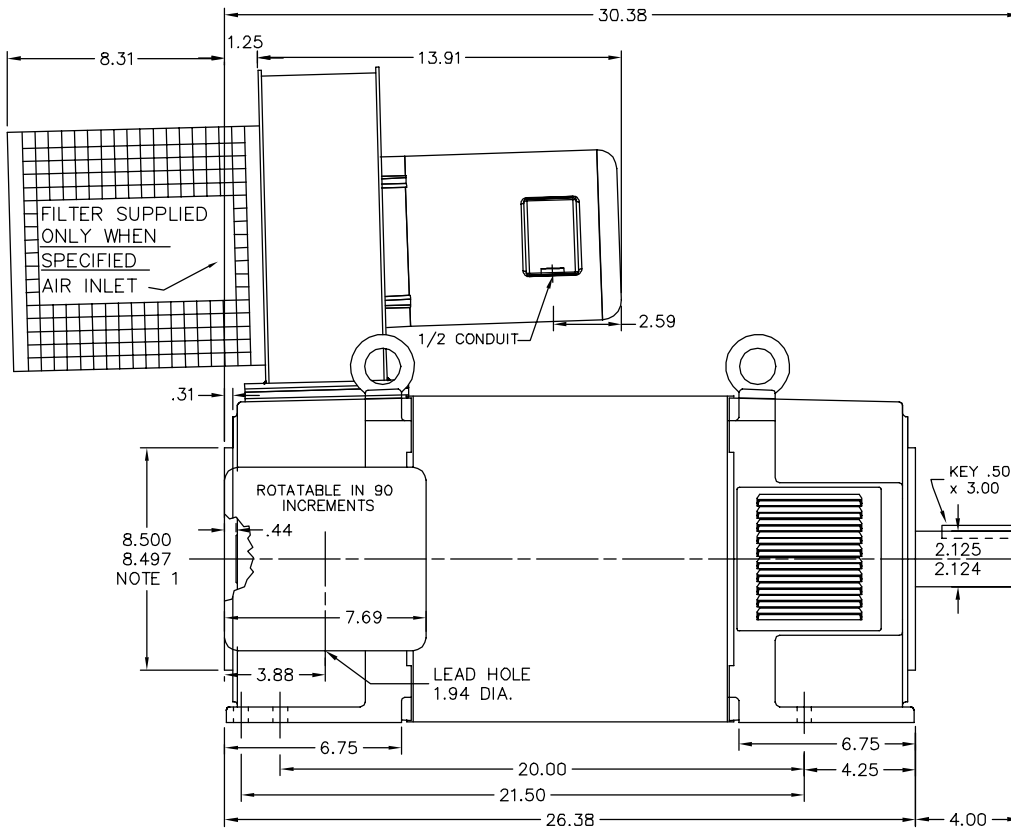

REFER TO MOTOR SPECIFICATION
 FOR LOCATIONS OF BLOWER
 3, 6, 9 OR 12 O'CLOCK AND
 CONDUIT BOX F1, F2 OR F3

BLOWER AND TERMINAL BOX MAY
 NOT BE IN THE SAME LOCATION.

DIMENSIONS ARE IN INCHES SCALE 1:1
 MOTOR WEIGHT 615 LBS. (MAY VARY 15%)

- NOTE 1 TACHOMETER MOUNTING
 1/2-13 TAP, .88 DEEP, ON A 7.25 DIA. BOLT CIRCLE
 FACE RUNOUT AND ECCENTRICITY .004 MAX. T.I.R.
- NOTE 2 SHAFT HEIGHT WILL NOT BE EXCEEDED.
 SHIMS UP TO .03 INCHES IN THICKNESS ARE USUALLY
 REQUIRED FOR COUPLED OR GEARED MACHINES.

121 AMP STEEL CONDUIT BOX SHOWN
 REFER TO 616779-50 FOR SPECIFIC CONDUIT BOX DIMENSIONS
 REFER TO 616779-51 FOR SPECIFIC TACHOMETER DIMENSIONS

CUSTOMER IS RESPONSIBLE FOR DETERMINING THAT THIS PRODUCT WILL PERFORM SUITABLY IN THE INTENDED APPLICATION.

REV. DESC: ADD BLOWER AND CONDUIT BOX LOCATION NOTE		
REV. LTR: B	VERSION: 02	TDR: 000001084751
FILE: \RGG\00003\589	REVISED: 07:15:06 09/25/2018	BY: RGGWT
MTL: -		

BALDOR - RELIANCE®

DIM SHT RL & URL2586Z RPM AC DPV PROV FOR TACH FT MTG

SH 1 of 1

617222-001